

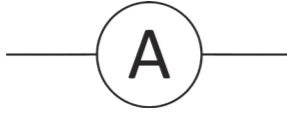



KS3 Electricity and Magnetism (Higher) **Revision Mat Answers**

Draw the circuit symbol for each component: a

ammeter 

battery 

bulb 

cell 

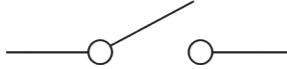
open switch 

voltmeter 

Write down the unit of measurement for each of the following: b

current **amps (A)**

potential **volts (V)**

resistance **ohms (Ω)**

Write down the equation that links current, potential difference and resistance.

resistance = potential difference ÷ current

Write a definition for each word: c

current

The flow of electric charge around a circuit.

potential difference

The amount of push (energy) provided by the battery to a moving charge.

Resistance

A measure of how difficult it is for a flow of charge to pass through a component.

Complete the table. d

Length of Wire (cm)	Potential Difference (V)	Current (A)	Resistance (Ω)
25	10	10	1
40	10	5	2
80	10	2	5

Explain how the length of a wire affects its resistance.

The longer the wire, the higher its resistance. This is because the electrons have a great distance to travel so collide with metal ions more often.

For each statement, tick the correct box to show if it is true or false. e

	True	False
In a series circuit, the current varies depending on where the ammeter is placed.	<input type="checkbox"/>	<input checked="" type="checkbox"/>
The more cells or batteries you add, the greater the current.	<input checked="" type="checkbox"/>	<input type="checkbox"/>
Eventually the current in a circuit will run out.	<input type="checkbox"/>	<input checked="" type="checkbox"/>
Potential difference is shared between the components in a series circuit.	<input checked="" type="checkbox"/>	<input type="checkbox"/>
In a parallel circuit, the current is divided between the branches.	<input checked="" type="checkbox"/>	<input type="checkbox"/>

For any statements that are false, write the correct statement.

Statement 1 - The current is the same everywhere in a series circuit.

Statement 3 - Current is not used up.

Draw the magnetic field lines around the bar magnet. f

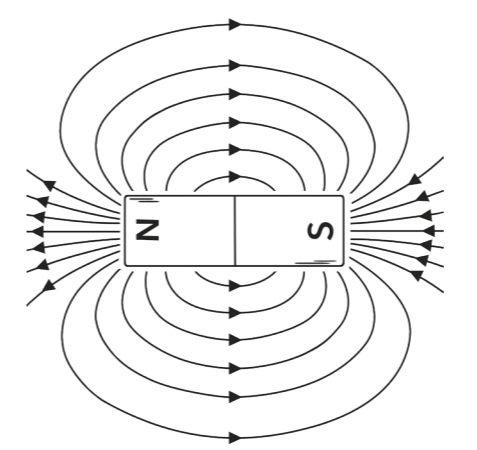

Draw a parallel circuit that would allow two bulbs to be switched on and off independently and the potential difference across each bulb to be measured. g

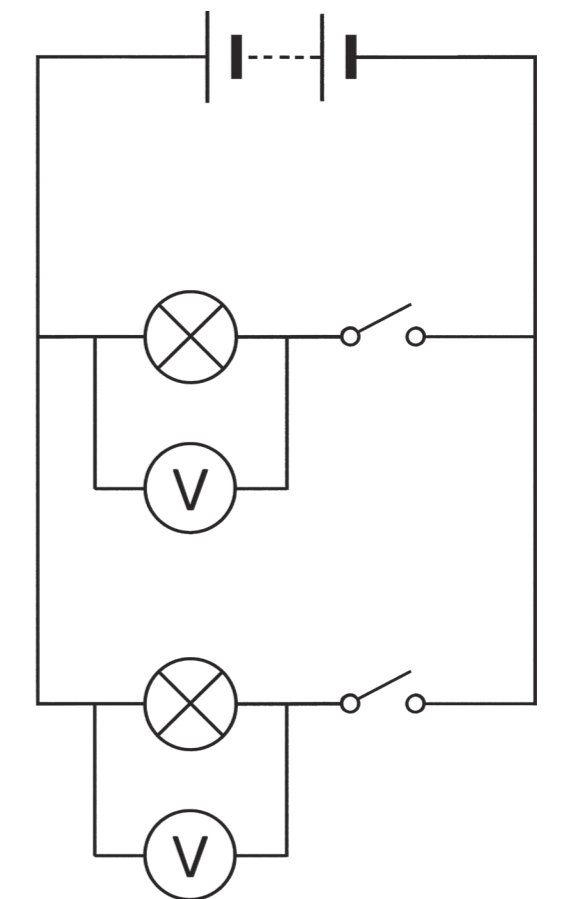

Explain why parallel circuits are used to wire homes instead of series circuits. h

Houses are wired using parallel circuits because the components in a parallel circuit are on separate branches. This allows the current several different paths for it to flow around.

If one bulb blows, the other bulbs will remain lit as the circuit is still complete.

Give the definition of each variable: i

independent variable

The variable you change in an investigation to see how it affects the dependent variable.

dependent variable

The variable you measure or observe for each change in the independent variable.

control variable

A variable that could affect the dependent variable so must be kept the same.

Give **one** advantage of using an electromagnet over a permanent magnet. j

An electromagnet can be switched on and off, allowing magnetic objects to be picked up and released easily.

Describe **two** ways you could increase the strength of an electromagnet.

- Increase the number of coils of wire around an iron core.**
- Increase the current supplied to the coil of wire.**

Write a method to investigate how the number of coils around an iron core affects the strength of an electromagnet. k

You should include any equipment you will need and the variables in your investigation.

Equipment:

- power pack**
- large nail/iron core**
- 30cm of insulated copper wire**
- 2 crocodile clips**
- 2 wires**
- 30 paperclips**

The independent variable is the number of coils of wire. The dependent variable is the strength of the electromagnet. This can be measured by counting the number of paperclips the electromagnet picks up. The control variables are the potential difference of the power pack, the current supplied to the coil of wire, the length of wire and the material of the core.

Method:

- Use a pair of wire strippers to remove some of the insulation from the insulated copper wire. Leave 2cm of exposed wire at each end of the copper wire.**
- Wrap the copper wire around the nail until you reach the required number of coils.**
- Attach the crocodile clips to the exposed wire.**
- Attach the opposite end of each wire to the terminals on the power pack.**
- Lay the paperclips on the bench and hold the insulated wire either side of the nail.**
- Turn on the power pack and hold the nail over the paperclips.**
- Record how many paperclips are attracted to the nail.**

The diagram below shows a model of a circuit. l

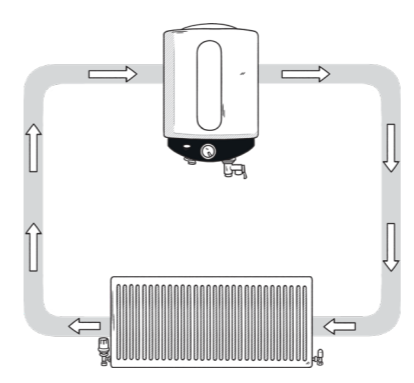

Suggest which part of a circuit is represented by each part of the model:

boiler and pump **cell or battery providing the 'push' to the circuit**

pipes **wires carrying the current around the circuit**

radiator **bulb (or other component) transferring energy to the surroundings**

Evaluate the use of the boiler and radiator model to represent a series circuit.

In the model, the pump pushes water around the system. The pump does a similar job to the battery pushing charges around the circuit.

There are pipes that carry the flow of water. Instead of water, the wires carry the flow of charges around the circuit. This is the electric current.

The bulb and the radiator are both very similar in that they transfer energy supplied by the circuit to the surroundings.

Label the diagram of an atom. m

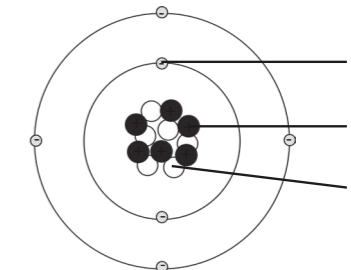

electron

proton

neutron

Give the charge of each subatomic particle.

Particle	Charge
electron	-1 / negative
neutron	0 / neutral
proton	+1 / positive

Explain why an atom has no charge overall.

The number of electrons is equal to the number of protons. Electrons have a charge of -1 and protons have a charge of +1 so the charges cancel each other out.

Explain what happens to an insulator that gains electrons. n

When a material gains electrons, it becomes negatively charged because electrons have a charge of -1.

Explain why a person's hair stands on end if they touch the dome of a Van de Graaff generator.

When the person touches the dome, electrons are transferred from the dome to the person's hair.

Their hair stands on end because each strand of hair is negatively charged and the same charges repel.

KS3 Electricity and Magnetism (Higher) **Revision Mat**

a Draw the circuit symbol for each component:

ammeter

battery

bulb

cell

open switch

voltmeter

c Write a definition for each word:

current

potential difference

resistance

d Complete the table.

Length of Wire (cm)	Potential Difference (___)	Current (___)	Resistance (___)
25	10	10	
40	10	5	
80	10		5

Explain how the length of a wire affects its resistance.

b Write down the unit of measurement for each of the following:

current _____

potential difference _____

resistance _____

Write down the equation that links current, potential difference and resistance.

e For each statement, tick the correct box to show if it is true or false.

	True	False
In a series circuit, the current varies depending on where the ammeter is placed.	<input type="checkbox"/>	<input type="checkbox"/>
The more cells or batteries you add, the greater the current.	<input type="checkbox"/>	<input type="checkbox"/>
Eventually the current in a circuit will run out.	<input type="checkbox"/>	<input type="checkbox"/>
Potential difference is shared between the components in a series circuit.	<input type="checkbox"/>	<input type="checkbox"/>
In a parallel circuit, the current is divided between the branches.	<input type="checkbox"/>	<input type="checkbox"/>

For any statements that are false, write the correct statement.

f Draw the magnetic field lines around the bar magnet.

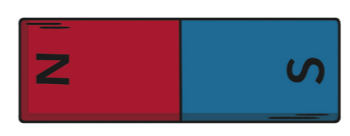

g Draw a parallel circuit that would allow two bulbs to be switched on and off independently and the potential difference across each bulb to be measured.

h Explain why parallel circuits are used to wire homes instead of series circuits.

Give the definition of each variable: i

independent variable

dependent variable

control variable

Write a method to investigate how the number of coils around an iron core affects the strength of an electromagnet. k

You should include any equipment you will need and the variables in your investigation.

The diagram below shows a model of a circuit. l

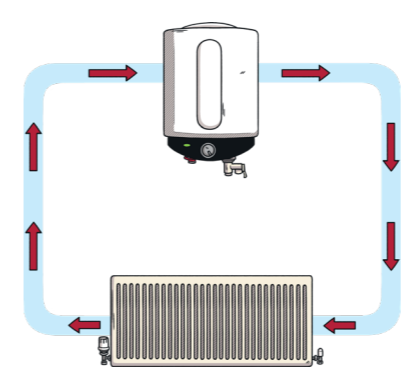

Suggest which part of a circuit is represented by each part of the model:

boiler and pump _____

pipes _____

radiator _____

Evaluate the use of the boiler and radiator model to represent a series circuit.

Give **one** advantage of using an electromagnet over a permanent magnet. j

Describe **two** ways you could increase the strength of an electromagnet.

1. _____

2. _____

Label the diagram of an atom. m

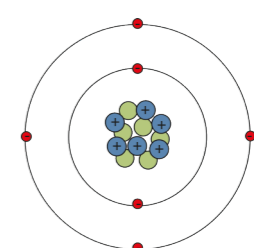

Give the charge of each subatomic particle.

Particle	Charge
electron	
neutron	
proton	

Explain why an atom has no charge overall.

Explain what happens to an insulator that gains electrons. n

Explain why a person's hair stands on end if they touch the dome of a Van de Graaff generator.
